





Welcome to the Iran Digital Printing Exhibition (IDPEX 2024)

*We Are Digital
We Are Future*

ABOUT US

Iran Digital Printing Exhibition (IDPEX) started its work in 2012 with the aim of introducing the capacities available in the digital printing market to printers, graphic artists and consumers of digital printing products and has completed 10 annual events of its activity so far.

During these years, more than 20,000 visitors have visited this exhibition, and more than 500 companies have joined us as exhibitors.

Iran Digital Printing Exhibition has attracted visitors from 30 provinces of Iran and managed to establish a good relationship with the consumers of digital printing products.

All kinds of devices and equipment for printing and consumables, as you may see on the page of "What you will see," have been presented in this exhibition, which have been welcomed by visitors.

Iran digital printing exhibition IDPEX has passed ten periods of its activity and its eleventh period will be held from June 29th to July 1st, 2024 in the Milad Tower exhibition complex.

Exhibition product group

- Outdoor printing machines
- Desktop publishing machines (copiers, laser and inkjet printers, etc.)
- Printing machines on hard objects
- Laminating and coating machines
- Additional operation machinery

- Cutting and engraving machines
- 3D printing machines
- Consumables for printing surfaces (textile, banner, flex, vinyl, mesh, PVC, etc.)
- Ink and printing ink
- Workflow systems

General conditions for attending the exhibition:

- Doing any kind of environmental advertising during the exhibition is subject to obtaining an independent license and paying the relevant fee.
- Participants can only install their advertising items within the privacy of their booth, and the use of corridor space or adjacent booths for this purpose is prohibited.
- It is prohibited to install or hang any banners, cloth writing, posters, or similar items from the ceiling of the hall.
- To carry out the advertisements mentioned in the above paragraph, the participants can install their advertising items on the wall or ceiling of the booth up to a height of 160 cm above their booth.
- If the number of participants does not reach the required quorum for any reason in such a way as to prevent the organization and holding of the exhibition, the organizer will be forced to cancel the exhibition and in this case, only the expenses paid to the organizer will be returned.
- These regulations are compiled based on cur-



rent rules and regulations in international exhibitions and by the conventions of exhibitions and are implemented in all valid exhibitions in the world. Failure to pay attention to them favors the organizer in pursuing legal action against the violators.

important points:

- The goods and products offered in the exhibition must be of suitable quality.
- In case of displaying heavy and bulky goods or the need for display machines and equipment with special dimensions or with a height of more than two meters, it is necessary to notify the headquarters in writing for the necessary coordination by mentioning the number, weight, and dimensions at the time of registration.
- In case of displaying heavy, bulky, or tall machines and devices, as well as machines with electricity consumption of more than five kilowatts, this should be notified and approved by the organizer thirty days before the opening.

Important dates:

- The deadline for registration is until the end of May 2024 (obviously, if the capacity of the covered halls is filled before the above date, the organizer will not accept new requests)
- Delivery of the booths for display goods arrangement and decoration inside the booth: 24 hours before the beginning of the exhibition
- Delivery of the space to self-made participants: 48 hours before the start of the exhibition
- Delivery of identification cards: one week before

the beginning of the exhibition

- Official opening of the exhibition: 10 am on May 7, 2024
 - Visiting hours of the exhibition: 10 am to 6 pm (if there is a change in the visiting hours, it will be announced by the organizer)
- Exiting the display goods from the exhibition area: from 9:00 am on June 6, the participants are required to leave their goods from the exhibition area and collect the booths after the end of the exhibition according to the schedule and hours announced by the organizer.
- Important note: the presence of the company representative is required from the opening of the doors of the halls to the complete gathering in the booth.

Registration fee:

The cost of exhibition booths in a covered hall equipped with prefabricated equipment (including surrounding panels, carpet, one outlet, lighting, one table, two chairs, inscription) is 250 euros per square meter (at least 9 square meters).

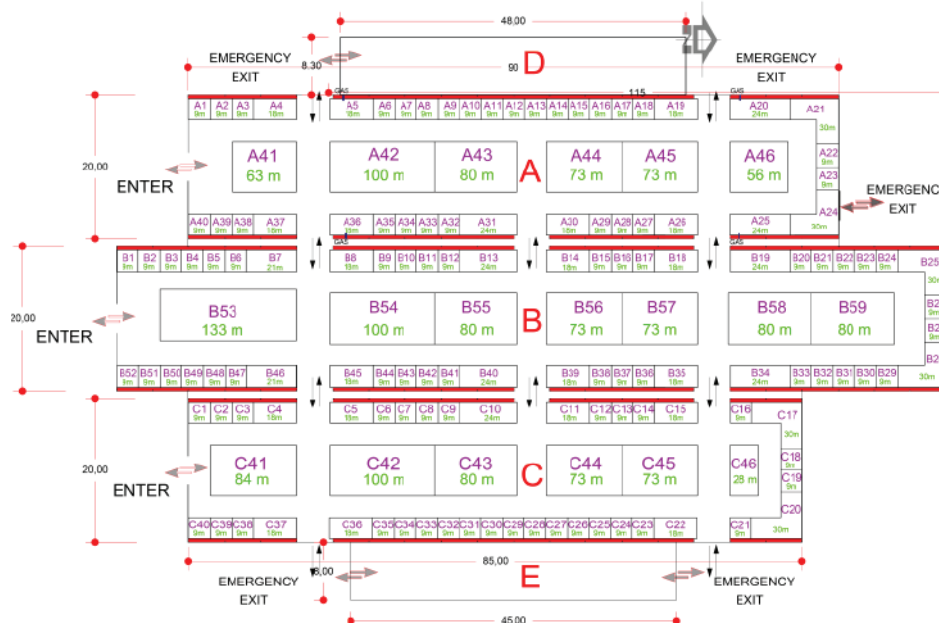
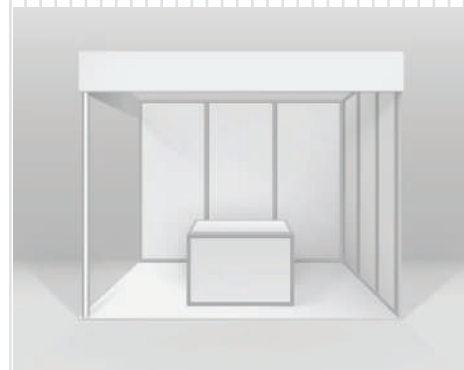

Floor Plan



We Are Digital
We Are Future

CONTACT

- +98 9120684162
- +98 21 88330248
- info@idpex.ir
- <https://idpex.ir/>
- No 1444, N Karegar St, Tehtan, Iran